

LIQUID AIR AS AN ENERGY STORAGE: A REVIEW

YVONNE LIM^{1,*}, MUSHTAK AL-ATABI¹, RICHARD A. WILLIAMS²

¹School of Engineering, Taylor's University, Taylor's Lakeside Campus,
No. 1 Jalan Taylor's, 47500, Subang Jaya, Selangor DE, Malaysia

²College of Engineering and Physical Sciences, University of Birmingham,
Edgbaston, Birmingham B15 2TT, United Kingdom

*Corresponding Author: yvonne.limhuili@sd.taylors.edu.my

Abstract

With the increasing demand for energy due to rapid industrialisation and the environmental concerns due to the usage of fossil fuels as the main energy source, there is a shift towards renewable energy. However, the intermittent nature of renewable energy requires energy produced during off-peak hours to be stored. This paper explores the use of liquefied air as an energy storage, the plausibility and the integration of liquefied air into existing framework, the role of liquefied air as an energy storage in addressing the Grand Challenges for Engineering as well as its employability in Malaysia.

Keywords: Liquid air, Energy storage, Liquefaction, Renewable energy, Grand challenges for engineering.

1. Introduction

Liquid air is air liquefied at -196°C at atmospheric pressure. Traditionally, air is separated to its constituents and the constituents such as oxygen and nitrogen are liquefied for industrial purposes, as well as storage and transport. However, the liquefaction of air, without the separation process; is being studied recently for its energy storage capabilities. Liquefying air would convert electrical energy to cold energy, stored and transported, if required; and then the energy can be extracted by expanding the air. This would convert the cold energy stored to kinetic energy to move turbines and generate electricity.

Energy storage is an important aspect of energy production, especially for renewable energy applications. Energy demand fluctuates throughout the day and various energy sources are used to supply the demand as seen in Fig. 1.

Abbreviations

CAES	Compressed Air Energy Storage
LAES	Liquid Air Energy Storage

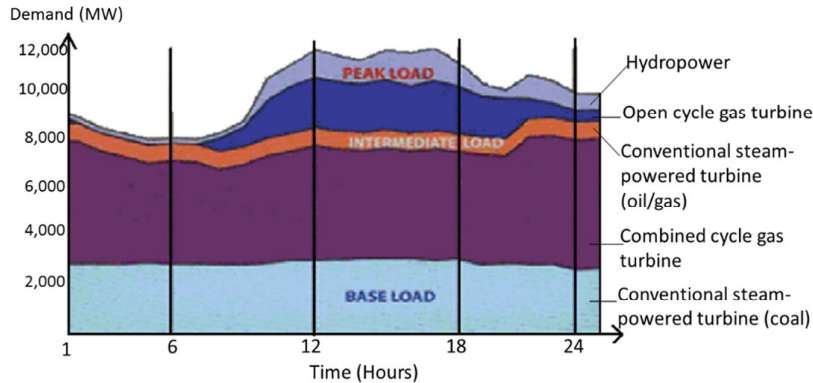
Typical Daily Weekday System Load Profile**Fig. 1. Energy demand curve in Malaysia.**

Therefore to maximise the efficiency of the power generation stations, energy management technologies are used. Energy management technologies are divided to supply side management and demand side management, where the supply or demand of energy is managed respectively. The figure above shows an example of supply side management. Energy storage is also a means of supply side management. Energy storage systems convert and store electrical energy when the power production exceeds the requirement and supply this energy during peak hours. This allows the energy production to remain at a relatively constant level to allow a more efficient operation.

The demand for energy is predicted to increase as rapid industrialisation and globalisation takes place, this may lead to an energy crisis. According to BP's 2013 review, the total amount of energy used in 2012 is 12,476 million tons of oil equivalent (Mtoe) [1] or 495 quadrillion Btu. One ton of oil equivalent is the energy released during the combustion of one ton of oil, giving an equivalent of 2.5×10^8 Btu. The energy consumption is projected to increase 1.6% per annum from 2012 to 2030, giving a total increase of approximately 35% of global energy demand [2]. Furthermore, these sources generate a lot of greenhouse gases which deplete the ozone layer during energy production [3]. Hence, a technological shift toward cleaner, non-exhaustible source of energy for energy production is underway to address the concerns of depleting fossil fuel on energy security and the environmental impact. Various types of renewable energy such as solar, wind, oceanic power, etc, have been developed as an alternative to fossil fuels.

Renewable energy however, is often either weather and/or location dependent, for example, solar energy is dependent upon the amount of sunlight present at a particular time and location, wind energy is often located in plain fields located far away from cities and wind speeds vary from time to time; therefore, the integration

of renewable energy into the grid poses a challenge. Off-peak energy generated by renewable sources is often wasted and energy generation on-site has to be delivered to the end users in the cities. Energy storage can be used to store and transport renewable energy and transport it to be used where and when required.

This review details the history of liquid air, the technologies involved in the liquefaction of air, various studies that have been carried out on cryogenic liquefaction, the overview of a liquid air economy and its feasibility in Malaysia, the current studies of the liquefaction technology, and the applications of these to the use of liquefied air as an energy storage, as well as in addressing the Grand Challenges for Engineering.

2. Energy Storage Systems

Energy vectors as mentioned above are methods of storing and transporting energy. Besides storing off-peak energy for renewable sources, energy storage systems are also required to balance the electricity load and supply curve. This helps even out the load distributions on the electricity production facilities, allowing it to function at conditions near its optimum conditions. Flywheel storage, batteries, supercapacitors, hydrogen storage, compressed air energy storage and pumped hydro are examples of energy storage technologies [4]. There are two ways of classifying energy storage systems, the first is by function, second is by form. Energy storage by function is grouped into two categories, power quality and reliability and energy [5].

Capacitors, supercapacitors, flywheel, batteries and superconducting magnetic energy storage system are examples of energy storage systems used for short time energy storage to ensure power quality and reliability of the supplied power [6]. On the other hand, pumped hydro storage, compressed air energy storage, large-scale battery, fuel cell, solar fuel and thermal energy storage are examples of energy management energy storage systems.

Energy storage can be categorised in terms of their form in which they store energy. Electrical energy storage includes electrostatic energy storage which are capacitors and supercapacitors and magnetic or current energy storage which includes superconducting magnetic energy storage. Mechanical energy storage stores energy in the form of kinetic energy and potential energy using flywheel and pumped hydro storage and compressed air energy storage respectively. Chemical energy storage systems store energy in the form of electrochemical energy, such as batteries; chemical energy, eg: fuel cells; and thermochemical energy storage, eg: solar metal, solar hydrogen. Thermal energy storage stores energy in the form of low temperature energy storage and high temperature energy storage. Examples of low temperature energy storage include aquiferous cold energy storage and cryogenic energy storage. Examples of high temperature energy storage include sensible heat systems such as steam or hot water accumulators, and latent heat systems such as phase change materials [5].

Cryogenically liquefied air functions as an energy management energy storage system and is a form of thermal energy storage. A study carried out by Li et al. compared the use of hydrogen, a chemical energy storage system, with cryogen energy storage systems, which includes liquefied air; to store oceanic energy. The

research studied the two forms in terms of efficiency of production, storage and transportation as well as energy extraction. The study showed that cryogenics have a better potential to be an energy carrier compared to hydrogen as it has fewer technical challenges to overcome and can be combined easily with renewable energies, is environmentally friendly and sustainable [7].

Cryogenically liquefied air is a cryogen and according to the second law of thermodynamics, the high grade cold energy stored in cryogenics is a more valuable energy source than heat [8]. Cryogenics store energy in the form of sensible and latent heat. Even though the specific heat and phase change heat of cryogenics and heat storage material is in approximately the same magnitude, cryogenics have higher exergy density, making it a better thermal energy storage medium.

3. Liquefied Air

Air consists of approximately 78% nitrogen and 21% oxygen, and thus has similar thermodynamic properties as nitrogen gas. Liquefied air is produced cryogenically, at -196°C , which is the boiling point of nitrogen; at atmospheric pressure. Liquefying air reduces the volume of air by 700 times. According to the Centre for Low Carbon Futures, liquid air has the potential of being an effective energy vector. Liquid air has been identified as a cheap, abundant and safe energy vector to store such energy [9].

Air can be liquefied when renewable energy produced is greater than the grid demand; this allows energy to be stored in the form of liquid air instead of being wasted. Liquefaction of air can also be carried out when the energy demand from the grid is low, e.g. Off-peak hours (at night or at wee hours of the morning); so it makes use of cheaper electricity tariffs to liquefy air.

Liquefied air can be stored in insulated vessels at low pressures and/or be transported to be used when and where required [5]. The liquefied air can then be regasified where and when excess energy is required. The expansion of liquid air can be used to run turbines which generate electrical energy from mechanical energy; it can also be used indirectly in Rankine or Brayton cycles as described in Section 5.

Figure 2 [10] shows the daily energy demand curve for a typical week in Malaysia and the troughs and peaks in which liquefied air can be produced and regasified. In Malaysia, for medium and high voltage industries, there are special tariffs for peak and off-peak consumption of electricity. For example, the electricity tariff for off-peak hours for medium voltage industries beginning 2014 is RM0.219 per kWh of electricity used, whereas the peak tariff is RM0.336 per kWh of electricity used [11]. This would save the company RM0.117 per kWh of energy used, which would translate to a large amount of savings over a period of time.

Since liquid air vaporises at -196°C , the heat required to regasify liquid air can be wholly attainable from the environment or using low grade waste heat from the industry. Liquefaction plants can be located near power plants, either renewable or conventional, or near industries, and it is not bound by geographical constraints [12].

One example of the employment of liquid air as an energy storage for power generation is the Highview Power Storage facility. It is a fully functional pilot plant connected to the UK power grid. It is hosted at the Slough Heat and Power biomass plant. The liquefaction plant utilises off-peak electricity from the

biomass plant to liquefy air, the liquid air is stored and regasified during peak electricity demand to generate power to supply to the grid [12].

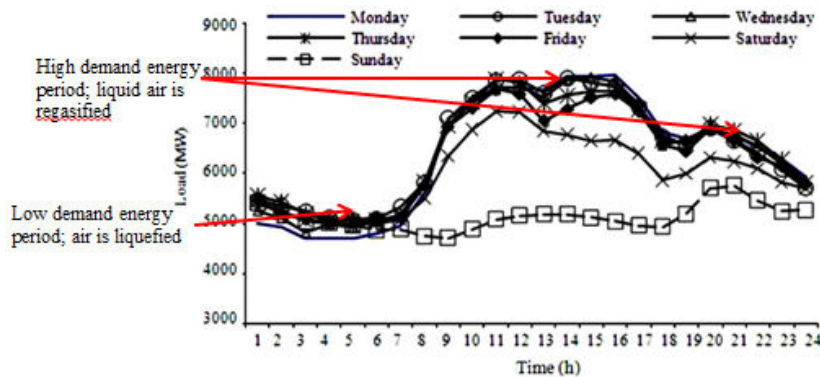

Fig. 2. Malaysian daily energy demand curve for a typical week [10].

4. Cryogenic Liquefaction Cycles

The use of liquefied gas has been employed in many important scientific and engineering processes which occur at cryogenic temperatures, temperatures below -150°C or 123K . Liquefaction of gases has been used to increase the density of gases to reduce the volume per unit mass for storage and transport. It also has many other applications depending on the gas. Cryogenic liquefaction of natural gas in base-load and peak shaving plants are used to store and transport natural gas [13]. Liquefied carbon dioxide is used in fire extinguishers; it is also used for oil recovery to aid the recovery of oil from oil wells. Liquid nitrogen is used as a cryopreservative of blood; and also in fire prevention systems in the industry [9]. Oxygen is liquefied for storage and for medical use. Recently, the development of using liquid air to be used as an energy storage [9]. There are many gas liquefaction cycles in the industry, however, they are not necessarily only limited to the only the gases they liquefy. Modifications can be done to cycles to allow them to liquefy air efficiently. This section gives an insight into the gas liquefaction processes available in the industry.

The Linde-Hampson cycle, also known as the Joule-Thomson cycle is the simplest of all cryogenic refrigeration processes [13]. Figure 3 shows the Linde-Hampson cycle. It is a self-refrigeration process. In stream 1, makeup gas mixes with uncondensed gas from the cycle. The mixture is compressed by an isothermal compressor, increasing the pressure of the mixture. The temperature is kept constant by rejecting compression heat to a coolant. The high pressure gas then enters the heat exchanger where the gas is cooled by the uncondensed gas. Exiting the heat exchanger, the gas is throttled through a throttle valve, the gas expands and the temperature of the gas decreases, condensing the gas. The resulting vapour-liquid mixture enters a phase separator where liquefied gas is removed and uncondensed gas is recycled [15].

A stream of gas to be liquefied can be run parallel to the streams in the heat exchanger co-current to the cold stream. This increases the heat transfer capacity of the cycle. Figure 4 shows the liquefaction of natural gas using the Linde-Hampson cycle.

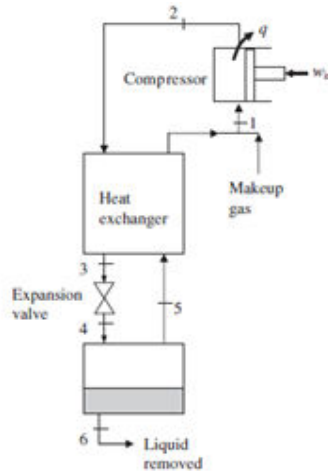

Fig. 1. Linde-Hampson Cycle [15].

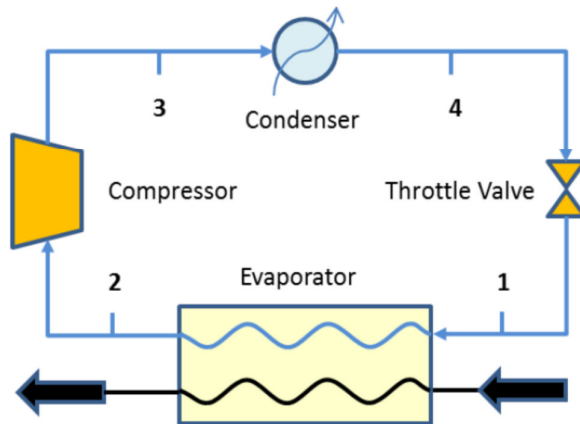

Fig. 2. Linde-Hampson cycle to liquefy natural gas [16].

Although the Linde-Hampson cycle is the simplest liquefaction cycle, it has shown to have very low exergy efficiencies. Modifications to the Linde-Hampson cycle to increase the exergy efficiency led to the development of the Claude cycle and the Collins cycle [13].

The Claude cycle and the Collins cycle is a modification of the Linde-Hampson cycle. The Claude cycle uses an expansion turbine in place of an expansion valve. Figure 5 shows the Claude cycle. The Collins cycle is mainly

used to liquefy helium. It uses two turbines unlike the Claude process which only uses one. Fig. 4 shows the Collins liquefaction process.

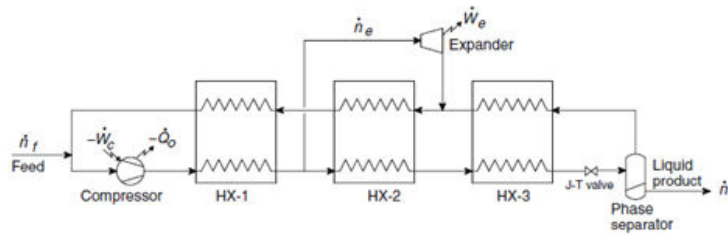

Fig. 3. Claude liquefaction cycle [13].

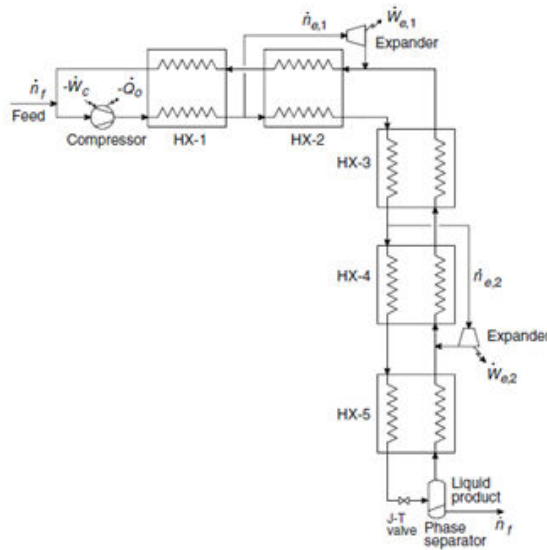

Fig. 4. Collins liquefaction process [13].

Cascade cycles are used when the difference in temperature of the cold and hot fluids is large and it is not possible to use only one pure refrigerant. Cascade cycles are generally used in the natural gas liquefaction cycles as natural gas consists of many different gases with different liquefaction temperatures. The cascade cycle as shown in Fig. 5 has one common heat exchanger; the internal cycle of the process cools the natural gas as well as the refrigerants in the external cycle. Cascade cycle refrigerants allows for temperature profile which is similar to the natural gas mixture, thus improving the cycle's coefficient of performance. The use of cascade cycles also provides better refrigerant load distribution, hence decreasing the work required and increasing efficiency. Cascade cycles however require more unit operations and hence higher start up and maintenance cost [16].

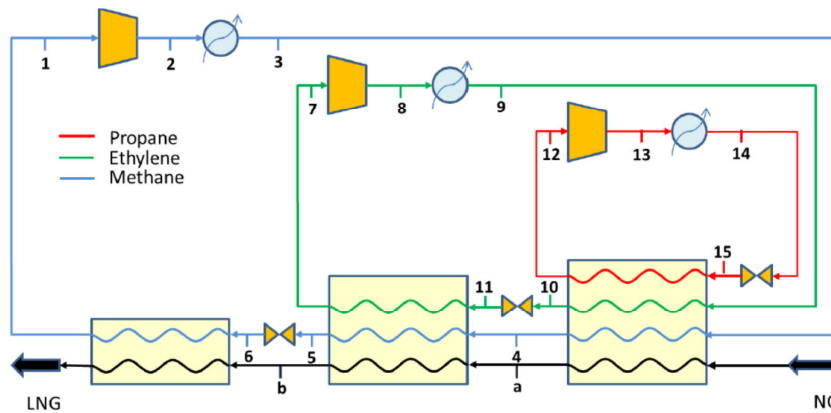

Fig. 5. Triple cascade cycle [16].

Mixed refrigerants are generally used in natural gas liquefaction processes. Mixed refrigerants are used to liquefy natural gas as natural gas is made up of various gaseous components, leading to a variable cooling curve. Hence, mixed refrigerants with components which will give a cooling curve closely matching the cooling curve of the natural gas is used to improve liquefaction efficiency [16]. Lately, research has been done to liquefy nitrogen using mixed refrigerant to increase the efficiency of the simple Linde-Hampson cycle. The study performed by Venkatarathnam shows the various mixed refrigerant mixtures and the operating temperature. This is compiled in Table 1. Hydrocarbon denotes a mixture of methane, ethane and propane [17].

Table 1. Liquefaction temperature and the refrigerant mixture.

Temperature (K)	Refrigerant mixture
70-120	Nitrogen-neon-hydrocarbon
80-120	Argon-nitrogen-neon-hydrocarbon
90-120	Nitrogen-hydrocarbon
120-150	Argon-hydrocarbon.

Fig8 shows a mixed refrigerant liquefaction cycle commonly used in natural gas liquefaction. A double pass for the refrigerant cycle is used to effectively control the temperature profile of the mixed refrigerant if intermediate separators are used for the formed vapours; so that the composition of the mixture can be regulated without disrupting the cycle operation.

Mixed refrigerant cycles are generally used in natural gas liquefaction cycles and have been recently employed in liquefying nitrogen. Mixed refrigerant cycles can be used to liquefy air as air consists of 78% by mole of nitrogen and hence have similar thermodynamic properties as nitrogen gas. A double pass refrigerant cycle may not be necessary as the composition of liquid air is constant and does not vary, unlike natural gas. Since air liquefies at -196°C, which is 77K, the mixed refrigerant should consist of a mixture of nitrogen, neon and hydrocarbon.

The use of mixed refrigerant to liquefy air could reduce the liquefaction pressure, making the process safer and more economical.

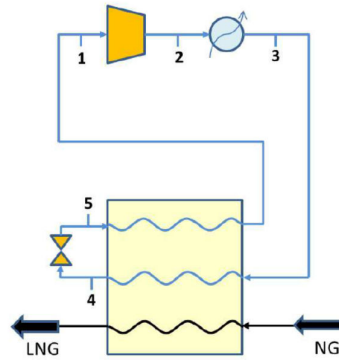

Fig. 8. Mixed refrigerant liquefaction cycle for natural gas [16].

The choice of the liquefaction cycle depends on its application; Table 2 gives the comparison of the efficiencies of the liquefaction cycles.

Table 2. Efficiency of liquefaction cycle for natural gas.

Liquefaction cycles	Maximum exergy efficiency (%)
Linde-Hampson cycle	27.8 [15]
Claude cycle	60 [13]
Cascade cycle	88.4 [35]
Mixed refrigerant cycle	59.3 (using Linde-Hampson cycle)
	63.4 (using Claude cycle) [13]

4. Extraction of Energy from Cryogenics

There are four main methods of energy extraction from cryogenics as summarised by Li et al. [8]. The four methods are direct expansion method, indirect Rankine cycle, indirect Brayton cycle, and the combined method.

The direct expansion method utilises cryogen pumped to a high pressure and then heated to atmospheric pressure using the surrounding heat or available waste heat. This is followed by the expansion process which drives turbines and generated power. This is the simplest but most inefficient method to extract energy from cryogenics. It does not fully utilise the cold energy possessed by the cryogen, energy is lost to the environment.

A Rankine cycle converts thermal energy, either hot or cold to work. The heat and cold sources are supplied externally to a closed-loop which utilises a phase change material as the working fluid. When a cryogen is used as the heat sink in the indirect Rankine cycle, it vapourises at a pressure that is at or slightly higher than the ambient pressure. A working fluid with a liquefaction/boiling point slightly higher than the cryogen would be an ideal working fluid to recover both the latent cold and sensible cold released by the cryogen. The Rankine cycle is effective method to extract the cryogenic energy if a working medium with a slightly higher boiling point than the cryogen is used. The Rankine cycle uses pumps to compress the working fluid, consuming a very small amount of work. Hence overall efficiency will not be affected much by the irreversible compression process. The recovery of cold released by the working fluid after compression has to be addressed to increase the efficiency. The cascading cycle can be a solution, but process optimisation is required to find a compromise between the efficiency and the complexity.

The indirect Brayton cycle is a thermodynamic cycle for gas turbines and engines. The Brayton cycle uses working fluid which is pressurised using a compressor instead of a pump in the Rankine cycle. The working fluid is a gas throughout the Brayton cycle. The heat or cold transferred to the working fluid is in the form of sensible heat or cold. The cryogenic energy can only be used to cool the inlet gas of the compressor. The Brayton cycle is not effective to directly recover cryogenic energy; this is because the cooling of the gas only requires sensible heat. Loss of cold exergy is inevitable during the heat transfer process which involves high grade latent heat even though the working fluid, the gas, can be cooled to a very low temperature.

The combination method is the combination of the direct expansion method and the Rankine cycle; the direct expansion method with the Brayton cycle; the Rankine and Brayton cycle; and the direct expansion method with the Rankine and Brayton cycle. It is a more effective way of extracting cryogenic energy. The thermal exergy of the cryogen is converted to high pressure exergy. The cryogen is pumped to a pressure above the critical point of the working fluid before vaporisation. This is followed by direct expansion to form a supercritical open cycle with only sensible heat discharged. For high grade heat sources, direct expansion-Brayton hybrid is the most efficient for most cryogenes except hydrogen. For ambient and/or low grade heat sources, direct expansion-Rankine cycle hybrid is more effective due to its low power consumption in the compression process [8].

A study was carried out by Zotter et al. to study the use of Rankine cycle variants on the energy extracted from liquid nitrogen energy storage system [6]. The study studied the efficiency of extraction of energy from liquid nitrogen liquefied using wind power. The first variant of the Rankine cycle is a semi-closed cycle with a compressor, heater, turbine, cooler, separator and throttle valve. The nitrogen which remains as a gas after passing through the throttle valve is vented into the atmosphere. The second variant uses three turbines in succession with a heater using ambient heat as the heat source. The second variant is an improvement of the first variant based on the study carried out on the first variant in which to obtain a high overall efficiency, a high turbine work is required and that any heat input does not influence the efficiency as heat is obtained from the surroundings. The first variant only gives an overall system

efficiency of 7.9%, with the improvements done on the second variant, an efficiency of 12.9% is obtained. Although the overall efficiency for liquefied air as an energy storage is low, the energy density of liquid nitrogen is approximately 10 times higher than compressed air energy storage. Furthermore, the use of liquid nitrogen as an energy storage requires nitrogen to be separated from atmospheric air, which requires a lot of energy. The direct use of air as an energy storage would reduce the energy required and therefore improve the efficiency. With more technological advances, liquid nitrogen may be a suitable energy vector for wind energy.

In 2013, a study was carried out by Ameel et al. to study the performance of a patented integrated Rankine-liquefaction cycle compared with a regular Rankine cycle. The integrated cycle utilises the cold from the liquefied air entering the Rankine cycle and the fraction of air which is not liquefied to reduce the temperature of the air entering the liquefaction cycle. The combined cycle had higher exergy efficiency as the liquefaction cycle utilised energy released from the Rankine cycle, making it a more efficient process. Energy recovered from the liquefied air using the Rankine cycle was 36.8% and that from the combined cycle was 43.3%, an increase of 6.5% recovery efficiency, using high grade heat of 800K may further increase the energy recovery of the process to approximately 70%. Although the improved efficiency is no match to the 75% recovery efficiency as obtained when using compressed air as an energy storage. However, the energy density of liquefied air as an energy storage is 20 times larger than compressed air energy storage. By developing isothermal compression and expansion as well as high efficiency heat exchangers, the competitive advantage of liquefied air as an energy storage may be increased [18].

5. Application of Cryogenics in Energy Production

There are industrial applications in power generation and energy storage using liquid air or nitrogen.

There have been attempts to utilise cryogenic liquids as a means to fuel vehicles but due to technological constraints and the rise of the internal combustion engine, efforts have stalled. The first liquid air powered engine was designed by the Liquid Air Company in the US in 1899. It was however bulky and inefficient and the emergence of the internal combustion engine and petroleum products resulted in the stop of the advancement of research into cryogenic engines until the 1970s during the oil crisis [9].

A liquid air turbine was patented in 1950. The turbine was designed specifically to run on liquid air as a driving medium. The motivation of the turbine was to remove the need for the use of internal combustion, hence making it a safer and cheaper process as material is not required to withstand high heat of combustion. Furthermore, the use of liquid air would release no pollutants to the atmosphere [19].

In 1969, Schwartzman patented a cryogenic engine system and method which uses cryogenic gases, this includes liquid air, liquid nitrogen, liquid hydrogen and liquid helium. The main objectives of the invention was to provide an engine system which is not subjected to the restraints of requiring energy to transfer the

cryogenic fuel; to provide high conversion efficiency; and to not utilise combustion and therefore reduce risks due to combustion. The system achieved a 73% Carnot efficiency using liquid nitrogen and liquid air, 93% for liquid hydrogen, 99% for liquid helium. This shows that cryogenics have a huge potential as an energy system [20].

A liquid air engine was patented in 1976 to be used in power plants. The purpose of using the liquid air engine is to not release any harmful substances into the atmosphere. The invention suggests the use of liquid air as the fuel to generate electricity in power plants using the expansion of liquid air to run turbine [21].

It can be seen that the use of liquefied air as an energy vector is not a novel thing. However, these have not taken flight since their conception. Recent advancement in technologies has propelled the feasibility of employing cryogenics as an energy store and to employ the energy stored to fuel vehicles, increasing its competitiveness with conventional energy systems.

In 1998, the University of North Texas built a car which runs on liquid nitrogen called the CoolN2Car which was modified to run using a closed Brayton cycle cryogenic heat engine. With a few modifications to the engine, the system is said to be able to run on liquid air [22].

In 2001, the Dearman engine was designed by Peter Dearman which utilises the vapourisation of liquid air in an engine cylinder to drive pistons to run a car. The technology is currently in its developmental stages but has the potential to replace petrol and diesel to power vehicles [9].

6. A Liquid Air Economy

According to the Centre for Low Carbon Futures' Liquid Air Technologies – Guide to the future report, there is a potential for liquid air to be integrated into existing infrastructures and employed for current use as well as a potential for further development to provide energy across the UK [23].

A cryogeniser is a power generator utilising cryogenically liquefied gases to generate electricity. It can be used as back-up or small scale generators to utilise liquefied gases. Besides that, a Dearman engine can also be used as a small scale generator.

Industrial gas producers can be pioneers in the cryogenic manufacturing and integration of liquefied gases in the company. Liquefiers can be run at night to liquefy unwanted industrial gases such as nitrogen from the separation of oxygen from air, utilising cheaper off-peak electricity. This liquefied gas can then be used on-site as auxiliary or backup generators to generate electricity.

Liquefied natural gas, LNG plants can also be used integrated into the liquid air economy. Waste cold generated from the liquefaction of natural gas can be used to cool air before entering the liquefaction process, reducing the power required to liquefy air.

Further development of liquid air can be integrated into existing infrastructures to reduce dependency on fossil fuels. The integration of liquefied air into existing infrastructure addressed the grand challenge of restoring and

improving existing infrastructure. Liquefiers could be placed in industrial parks, low grade waste heat ($<100^{\circ}\text{C}$) from the surrounding factories can be used to provide heat to expand liquefied air to generate electricity for the industrial park. Liquefied gases can also be transported elsewhere to be used. Datacentres can use liquefied air for cooling the electrical components as well as for a backup cryogenet. Logistic companies can use liquefied air in Dearman engine forklifts and hybrid lorries. Supermarket distribution hubs can utilise liquefied air as a backup cryogenet in case of emergencies as well as in Dearman engine refrigeration unit trucks to run the trucks as well as keep food items fresh.

A liquid air economy can also be integrated into Malaysian infrastructure. Malaysia, being a tropical country with a hot climate all year round relies heavily on air-conditioning to regulate the indoor temperature. The integration of liquid air as an energy storage would benefit largely from it as bulk of the energy needs of business and organisations comes from air-conditioning. The use of liquid air in buildings as an energy storage for cryogenet in case of emergencies or to reduce dependence on the grid when extra power is required, the liquid air can be circulated around the building to reduce the ambient indoor temperatures. The heat required for expansion of liquid air can be obtained from the sun and this requires so other additional heat energy.

Data centres are continually being outsourced from developed countries to developing countries such as Malaysia. According to the MSC, it is projected that approximately USD 10.9 billion worth of data centres are to be in the South East Asian region. Malaysia aims to obtain a large slice of this market by increasing its total area of data centres from 46,452 m^2 (0.5 million sq-ft) to 464,520 m^2 (5 million sq-ft) by 2020. There are currently 16 companies which have data centres all over the nation specialising from disaster recovery to cloud computing to storage. Many of these companies implement green technology measures to reduce the environmental impact to the environment such as buildings which are insulated from the outdoor heat and water cooling systems [24]. Liquid air technology for backup power generation would provide security against power outages and also provide a cooling medium for the data centres, reducing its overall cooling load.

Malaysia is a country blessed with natural resources, one of which is natural gas. Malaysia currently has three functioning natural liquefaction plants, which makes up the Petronas LNG complex in Bintulu, Sarawak. It is one of the largest liquefaction plants in world. The utilisation of this cold energy generated to precool air before liquefaction to reduce the energy required to liquefy air. Bintulu is a coastal town and a popular nature and wildlife tourist attraction. The use of liquefied air produced from these LNG plants to generate electricity would for tourist spots would reduce the environmental impact of these commercialisations to the environment. Liquefied air can also be used to generate electricity using cryogenets in more rural areas of Sarawak, hence providing the rural folk with modern amenities which would improve the quality of life.

The Malaysian renewable energy scene is growing, the amount of renewable energy generated is targeted at 986 MW of power or 5.5% of the total energy produced by 2015 [25]. However, as of September 2012, only 74 MW of renewable energy is connected to the grid, whereas 430 MW of energy is produced and used off-grid by palm oil millers and solar hybrid systems. The Sustainable Energy

Development Authority (SEDA) in Malaysia has set a set a feed-in tariff for various renewable energies into the grid to meet the 5.5% targeted renewable energy. 43% of total capacity of solar energy generated, 26% of biomass and 5% of biogas is targeted to be fed into the national grid [26]. As mentioned above, renewable energy is intermittent in nature and restricted by location, hence, there are opportunities to utilise liquid air as an energy storage for transport and storage of these renewable energies to the grid. This would reduce the “wrong-time” energy wastage and make renewable energy in Malaysia more viable.

There are many potential uses for liquefied air, but like all new technologies, it has to “cross the chasm” so to speak from the early adopters to the mass market for the technology to be widely accepted by the general public in the UK and in Malaysia. To do this, industries and businesses must be well informed about the economic potential of employing liquefied air in their various business activities, the return on investment and the financial gains which may be expected.

7. Studies on Gas Liquefaction Processes

As seen above, liquefied air has a large potential as an energy storage system. However, there are still various technical challenges faced especially those pertaining to the efficiency of the liquefaction system and the extraction of energy. There have been various studies carried out on liquefaction processes, in this section the research carried out liquefaction of various gases will be discussed.

Many studies have been carried out by various researches studying the performance of liquefaction cycles and how to optimise the cycles by increasing the exergy efficiency of the cycle. Most research in gas liquefaction are carried out to model and assess the natural gas liquefaction processes as it is the most widespread liquefaction process in the industry and the most profitable, however there are also studies on other gas liquefaction cycles.

Konoglu et al. modelled the Linde-Hampson cycle to liquefy air. The study assumed oxygen to be the component in air which is liquefied. Konoglu et al. employed numerical calculations to obtain performance parameters of air and parametric studies were employed to study the effects of liquefaction and inlet gas temperature on first and second law of thermodynamics parameters. They found that increasing the liquefaction temperature and decreasing the inlet gas temperature increases the mass fraction of gas liquefied, the coefficient of performance and exergy efficiency while decreasing the energy consumed. The study suggested that the method can be used to model other gas liquefaction process [15].

Morin et al. optimised the energy efficiency of the natural gas liquefaction process using the evolutionary search method. The PRICO process and the TEALARC process were modelled. The PRICO process is a simple liquefaction process whereas the TEALARC process is a complicated process with many variables. The evolutionary search method uses the theory of evolution to select the optimal process conditions. The simulations were carried out using ASPEN HYSYS. It is found that modelling complicated processes like the TEALARC process using the evolutionary search method to find the optimal conditions require less time and fine tuning [27].

The modelling and simulation of natural gas liquefaction process were carried out by Trigilio et al. The simulation was performed using Matlab. The thermodynamic model for vapour-liquid equilibria and the energy properties was calculated using the Peng and Robinson equation of state for the work and heat calculations. The study modelled liquefaction of natural gas using cascade cycles and using a regular cycle using a mixed refrigerant to determine the variables which affect the process the most using sensitivity analysis. The study suggested that the variable most affecting the cascade cycle is the high pressure of the external cycle and that most affecting the mixed refrigerant cycle is the high pressure of the cycle [16].

Optimal designs for natural gas liquefaction plants have also been carried out using genetic algorithm. A study carried out by Li et al. utilised a developed genetic algorithm based optimal design method using Matlab for building a large scale gas liquefaction system by increasing the exergy efficiency of the process. In the study, the exergy efficiency of a liquefaction process would increase as the number of generation cycles increase up to 40 generations of liquefied gas. The exergy efficiency would also increase if an optimised heat exchanger network is used, liquefaction efficiency can be increased by using a cryoturbine instead of a throttle valve. Cryoturbines reduces cold requirement of the process and produces addition shaft power. A genetic algorithm based optimal design method as shown in the study can be used to increase the efficiency of a liquefaction process by suggesting a suitable configuration and operating conditions [28].

Studies involving Mixed Refrigerants in Liquefaction Cycles

Studies on optimisation of mixed refrigerant processes for liquefaction of natural gas have also been very widespread. A study on the design optimisation of a single mixed refrigerant for natural gas liquefaction process using particle swarm paradigm with nonlinear constraints was carried out by Khan and Lee [29]. Particle swarm paradigm, PSP, coded in Matlab is a non-calculus based model which can solve discontinuous, multimodal, non-convex challenges; it has few adjusting parameters and functions well with a variety of applications which makes it attractive to use. The single mixed refrigerant natural gas liquefaction process was optimised using the paradigm by manipulating the key decision variables between fixed bounds while satisfying the constraints. This was done to reduce the compression energy requirement. The PSP obtained values of optimising variables that ensured a small temperature difference between the hot and cold stream inside a heat exchanger, resulting in an increase in exergy efficiency.

Mixed refrigeration cycles are also employed in liquefied natural gas floating, production and offloading units, LNG FPSO. The feasibility of using dual mixed refrigerant instead of single mixed refrigerant in LNG FPSO has been looked into. The study was employed to minimise the compressor power needed in the dual mixed refrigerant cycle using a mathematical model developed using hybridisation optimisation method consisting of a genetic algorithm and sequential quadratic programming. The study compares the conditions obtained from the mathematical model with that of the study by Venkatarathnam in 2008. The results obtained showed a 1.2% decrease in power using the operating conditions obtained as compared to the study by Venkatarathnam [30].

The use of mixed refrigerants in multi-stream heat exchanger has also been studied. Chang et al. studied the effect of using a multi-stream heat exchanger on the performance of natural gas liquefaction using a single-stage mixed refrigerant process. The study focused on how the temperature profile generated by process modelling software, HYSYS, differs from the actual temperature profile and how it affects the thermodynamic performance of liquefaction. The study showed that the temperature profile generated using HYSYS and a minimum temperature approach is difficult to achieve in practical multi-stream heat exchangers, however it is achievable if proper heat-exchanger design is employed. For an efficient liquefaction process, no direct heat exchange between hot streams in a three stream heat exchanger is suggested [31].

Many assumptions were made when simulating the processes. One of the assumptions made was that the heat exchanger functions at 100% efficiency and that the compressor is adiabatic. In reality, there is no such thing as an ideal heat exchanger. Heat is lost to the surroundings. There may be heat leaks in the compressors leading to non-adiabatic conditions. This will affect the simulation results. Furthermore, the properties of the mixed refrigerants are predicted by the fluid packages available in the software used, the accuracy of the properties may vary from each program, hence affecting the accuracy.

8. Suggested Further Studies on Liquefaction of Air

Many of the researches mentioned above are carried out on natural gas liquefaction processes, and not many are carried out on the energy storage ability of cryogenic gases. In order for liquid air technologies to achieve the efficiency required to rival other energy storage systems.

Studies can be carried out to incorporate power recovery together with liquefaction in order to maximise the use of the power input for liquefaction, hence increasing the overall efficiency of the process. The incorporation of the power recovery and liquefaction cycles to meet the demand of the local energy grid is also an interesting prospect to venture into. It investigates the feasibility and practicality of the technology into an existing system, liquefying air when there is excess in power generation and regasifying air for power recovery during peak hours of electricity usage.

Another technical aspect of liquefaction that can be looked into is the scale effect of scaling down large liquefaction plants. Scale-ups in engineering design is a common practice, however, scaling down from an existing design isn't given much attention. To scale down an existing liquefaction plant for local use such as in factories and neighbourhoods is an important factor in the realisation of a liquid air economy. Miniaturisation of liquefied natural gas plant is being implemented in floating LNG platforms. Shell has just commissioned the voyage of Prelude, a floating natural gas production platform planned to be operated off the Australian shoreline [32]. Building the Prelude is said to be a challenge as engineers have to design a working liquefaction plant to fit $\frac{1}{4}$ the size of regular onshore liquefaction plants. Similar challenges would be faced when scaling down an air liquefaction plant for local use.

Storing liquid air is doesn't pose much of a challenge as there are existing cryogenic gas storage specifications. Cryogenic storage vessels are double walled

cylindrical tanks which a space in between the two walls containing an insulating material. There is a need for the design of a more efficient thermal material for these storage tanks to improve the insulation of the tanks, especially for the use in tropical countries such as Malaysia where the ambient temperature is 29-32°C.

Air-conditioning systems and refrigeration systems have been an integral part of modern day life for daily living to cool indoor spaces and to store food. It also makes up bulk of the worldwide energy demand. If liquefied air energy storage can be integrated to the cooling needs of the world, it would reduce the energy demand, making liquefied air energy storage a more attractive method of supplying power. Future studies on the incorporation of liquid air as an energy storage may be a move to make liquefied air more commercially and economically acceptable.

Furthermore, there is a need to develop a business model for liquefied air energy storage systems; showing the potential economic viability of liquefied air in order for investors, business and venture capitalist to fund the research and pilot projects to integrate liquid air into existing infrastructure. A business model would ease the transition of liquid air technology to “cross the chasm” from research to large scale implementation.

9. Addressing the Grand Challenges for Engineering with Liquefied Air as an Energy Storage

The Grand Challenges of Engineering is a set of 14 challenges identified by the National Academy of Engineers in the USA which need to be addressed in order for humanity to sustainably move into the 22nd century [33]. This project addresses the grand challenges of making solar energy affordable and restoring and improving urban infrastructure.

Malaysian climate has long periods of sunshine for most of the year, making solar power a very viable renewable energy option to replace fossil fuels [34]. However, there is a need to find a cheaper alternative to the current technologies. The use of liquefied air as an energy storage has the potential to reduce the cost of solar energy. Solar energy is weather and time dependent, ie we don't get much sunlight when it rains, there is no sunshine at night; hence, there is a need to store solar energy when the supply of solar energy is larger than the demand. Air can be liquefied using the excess solar energy during this period. This enables the solar energy which would otherwise be wasted to be utilised, this allows for a shorter return on investment period for solar energy, making it more affordable.

Infrastructure includes the buildings, facilities such as water, sewage and electricity; and transportation in an area. Current infrastructures in major cities around the world have high fossil fuel usage due to industrialisation and modernisation. More energy is required to power data centres for the increasing use of the World Wide Web, more petrol is required to fuel the millions of cars on the face of the planet. This impacts the environment in a major way. The integration of liquefied air as discussed above can improve the current state of the infrastructure; it reduces the reliance on fossil fuels by using more renewable sources. The use of renewable energy to power cities would reduce the environmental impact, making the modern lifestyle more sustainable.

10. Conclusion

The review paper gives an overview of liquefied air, the potential it has as an energy storage system, the current work that is being done in the space, the technologies involved, the applications in Malaysia, as well as how it addresses the Grand Challenges for Engineering. These are summarised below.

- It is seen that liquefied air has the potential of being an effective and competitive energy storage system. The technology involved in liquefaction has been widely employed in the industry and hence converting existing systems to liquefy air would not pose large challenges.
- Liquefied air as an energy storage also has the potential of propelling renewable energy usage in Malaysia as well as globally to greater heights by utilising wrong time energy instead of letting it go to waste, thus reducing the dependence on fossil fuels.
- However, much research still has to be conducted to make liquid air a competitive energy storage system. The possible integration of power recovery into air liquefaction systems and its connectivity to the grid is an interesting prospect and a valid avenue to pursue.
- The effect of scaling large scale liquefaction plants down for more localised used should also be given attention to.
- Liquefied air also has the potential to make a dent in addressing the Grand Challenges for Engineering in terms of making solar energy affordable and also to improve urban infrastructure.

References

1. BP (2013). BP Statistical Review of World Energy.
2. BP (2013). BP Energy Outlook 2030.
3. Ong, H.C.; Mahlia, T.M.I.; and Masjuki, H.H. (2010). A review on energy scenario and sustainable energy in Malaysia. *Renewable and Sustainable Energy Review*, 15, 639-647.
4. Hadjipaschalis, I.; Poullikkas, A.; and Efthimiou, V. (2009). Overview of current and future energy storage technologies for electric power applications. *Renewable and Sustainable Energy Reviews*, 13, 1513-1522.
5. Chen, H.; Cong, T.N.; Yang, W.; Tan, C.; Li, Y.; and Ding, Y. (2009). Progress in electrical energy storage system: A critical review. *Journal of Progress in Natural Science*, 19, 291-312.
6. Zotter, G.; Hermeling, W.; and Sanz, W., Thermodynamic analysis of a novel cryogenic rankine cycle for wind energy storage (2012). *Proceedings of the ASME Turbo Expo 2012*. Copenhagen, June 11-15.
7. Li, Y.; Chen, H.; Zhang, X.; Tan C.; and Ding Y. (2010) Renewable energy carriers: Hydrogen or liquid air/nitrogen? *Journal of Applied Thermal Engineering*, 30, 1985-1990.
8. Li, Y.; Chen, H.; and Ding, Y. (2010). Fundamentals and applications of cryogen as a thermal energy carrier: A critical assessment. *International Journal of Thermal Sciences*, 49(6), 941-949.

9. Centre for Low Carbon Futures (2013). Liquid Air in the energy and transport systems: Opportunities for industry and innovation in the UK. Full Report. ISBN: 978-0-9575872-1-2
10. Ismail, Z.; Yahya, A.; Mahpol, K.A. (2009). Forecasting peak load electricity demand using statistics and rule based approach. *American Journal of Applied Sciences*, 6(8), 1618-1625.
11. Tenaga Nasional Berhad (2013). Malaysian Industry Energy Tariffs.
12. IMechE (2011). Highview Power Storage: Secure, Clean Power. Retrieved September 20, 2013 from http://www.imeche.org/docs/default-source/2011-press-releases/Highview_2pager.pdf?sfvrsn=0
13. Venkatarathnam, G. (2008). *Cryogenic Mixed Refrigerant Processes*. New York: Springer.
14. Balmer, R. (2011). *Modern Engineering Thermodynamic*. Amsterdam: Elsevier.
15. Konoglu, M.; Dincer, I.; and Rosen, M.A. (2008). Performance analysis of gas liquefaction cycles. *International Journal of Energy Research*, 32, 38-43.
16. Trigilio, A.; Bouza, A.; and Di Scipio, S. (2012). Modelling and Simulation of Natural Gas Liquefaction Process. In: H. Al-Megren, ed. *Advances in Natural Gas Technology*, InTech, DOI. Ch 8.
17. Venkatarathnam, G. (2008). Liquefaction of nitrogen using mixed refrigerant processes. Refrigeration and Airconditioning Laboratory, Department of Mechanical Engineering, Indian Institute of Technology, Madras.
18. Ameel, B.; T'Joel, C.; De Kerpel, K., De Jaeger, P., Huisseune, H., Van Belleghem, M., and De Paepe, M. (2013). Thermodynamic analysis of energy storage with a liquid air Rankine cycle. *Journal of Applied Thermal Energy*, 52, 130-140.
19. Osbourne, E., 1950. *Liquid Air Turbine*. US Patent 2499772.
20. Schwartzman, E.H., 1969. *Cryogenic Engine Systems and Methods*. US Patent 3451342.
21. Pereda, E., 1976. *Liquid Air Engine*. US Patent 3987632.
22. Ordonez, C.A. (2000). Liquid nitrogen fuelled, closed Brayton cycle cryogenic engine. *Journal of Energy Conversion and Management*, 41, 331-341.
23. Centre for Low Carbon Futures (2013). Liquid Air Technologies – A guide to the potential. ISBN: 978-0-9927328-0-6.
24. MSC Malaysia (2013). Malaysia: A World Class Hub for Data Centres.
25. Shafie, S.M.; Mahlia, T.M.I.; Masjuki, H.H.; and Andriyana, A. (2011). Current energy usage and sustainable energy in Malaysia: A review. *Renewable and Sustainable Energy Reviews*, 15, 4370-4377.
26. Webb, S. (2013). Malaysia: Renewable energy in the Asia Pacific: a Legal Overview. DLA Piper Australia.
27. Morin, A.; Wahl, P.E.; and Molnik, M. (2011). Using evolutionary search to optimise the energy consumption for natural gas liquefaction. *Journal of Chemical Engineering Research and Design*, 89, 2428-2411.
28. Li, Y.; Wang, X.; and Ding, Y. (2012). An optimal design methodology for large-scale gas liquefaction. *Journal of Applied Energy*, 99, 484-490.

29. Khan, M.S. and Lee M. (2013). Design optimization of single mixed refrigerant natural gas liquefaction process using the particle swarm paradigm with non-linear constraints. *Journal of Energy*, 49, 146-155.
30. Hwang, J.-H., Roh, M.-I., and Lee, K.-Y. (2013). Determination of the optimal operating conditions of the dual mixed refrigerant cycle for the LNG FPSO topside liquefaction process. *Journal of Computers and Chemical Engineering*. 49, 25-36.
31. Chang, H-M.; Lim H.S.; and Choe, K.H. (2012). Effect of multi-stream heat exchanger on performance of natural gas liquefaction with mixed refrigerant. *Journal of Cryogenics*, 52, 642-647.
32. Shell (2013). Prelude FLNG – An Overview.
33. National Academy of Engineering (2008). Introduction to the Grand Challenges for Engineering.
34. Mekhilef, S.; Safari, A.; Mustafa, W.E.S.; Saidur, R.; Omar, R.; and Younis, M.A.A. (2012). Solar energy in Malaysia: Current state and prospects. *Renewable and Sustainable Energy Reviews*, 16, 386-396.
35. Karakurt, A.S.; Gunes, U.; Arda, M.; and Ust, Y., 2014. Exergetic Performance Analyses of Natural Gas Liquefaction Processes. In *2nd International Symposium on Naval Architecture and Maritime*. Istanbul, October 23-24.